

3.3传动与操纵Propeller Shaft &Transmission Operation System

序号/ No.	名 称 / Designation		页 码 /Page No.
3.3.01	HW18710变速器软轴操纵装置/Flexible Cable Shift System		1
3.3.02	离合器液压操纵装置/Operating System		3
3.3.03	HOWO组合踏板操纵装置(新开关/共轨)/Pedal Control Device		4
3.3.04	传动轴/Propeller Shaft		7
3.3.05	变速器辅助支撑/Transmission Support		8

3.3.01 HW18710变速器软轴操纵装置/Flexible Cable Shift System

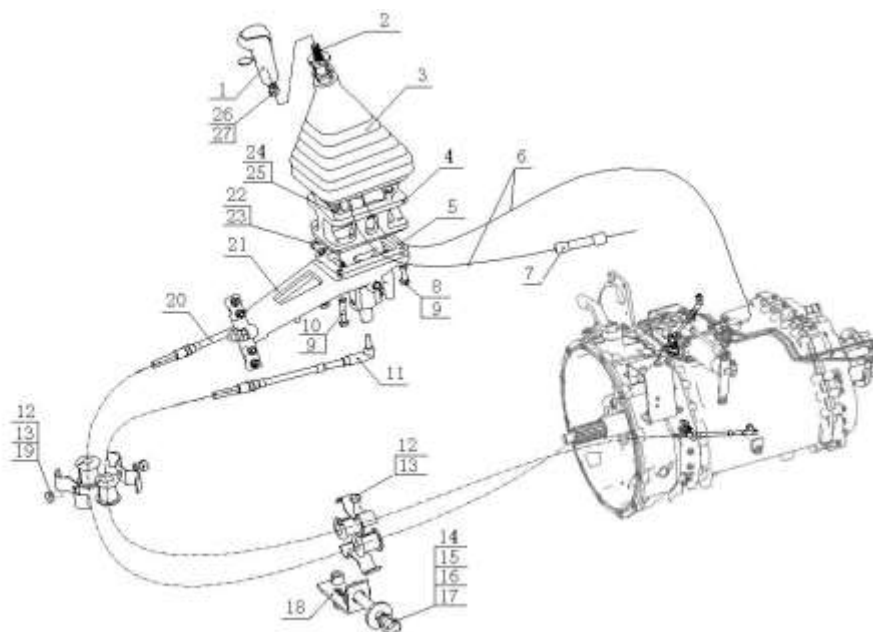

3.3.01 HW18710变速器软轴操纵装置/Flexible Cable Shift System

序号 No.	零部件图号 Part No.	名称	Part Name	数量 Qty	备注 Remark
1	WG9925240020	变速器换挡手柄及挡位标牌总成	Shifting handle and gear ind	1	From 20110107
1	WG9700240015	变速器换挡手柄及挡位标牌总成	Shifting handle and gear ind	1	To 20110107
2	AZ9700240078	变速器操纵杆	Rod	1	From 20110107
2	AZ9725240125	变速器操纵杆	Rod	1	To 20110107
3	AZ9700240077	防尘罩	Dustproof cover	1	From 20110107
3	AZ9725240101	防尘罩	Dustproof cover	1	To 20110107
4	AZ9725240102	操纵器连接块（左置车）	Block	1	
5	AZ9725240119	纸垫	Paper gasket	2	
6	WG9700240006	变速器手柄气管	Air pipe	1	
7	WG9700240003	6/4快插变径接头	Connector	1	
8	Q150B0830	六角头螺栓	Screw	2	
9	Q40308	弹簧垫圈	Spring washer	4	
10	Q150B0845	六角头螺栓	Screw	2	
11	WG9725240202	换挡软轴总成（3300）	Flexible cable ass.-select ge	1	From 20101125
11	WG9719240034	换挡软轴总成（H0W08）	Flexible cable ass.-select ge	1	To 20101125
12	Q340B06	I型六角螺母	Nut	2	
13	Q40306	弹簧垫圈	Spring washer	2	
14	Q40310	弹簧垫圈	Spring washer	1	
15	Q340B10	六角螺母	Nut	1	
16	Q40210	大垫圈	Washer	1	

17	Q150B1035	六角头螺栓	Screw	1	
3.3.01 HW18710变速器软轴操纵装置/Flexible Cable Shift System					
3.3.01 HW18710变速器软轴操纵装置/Flexible Cable Shift System					
序号	零部件图号	名称	Part Name	数量	备注
No.	Part No.			Qty	Remark
18	WG9718360017	五孔支架	Bracket	1	From 20110107
18	WG9325240014	支架	Bracket	1	To 20110107
18	WG97 350169	角形支架	Bracket	1	To 20101125
19	Q150B0610	六角头螺栓	Screw	1	
20	WG9725240204	选档软轴总成 (3400)	Flexible cable-select gear	1	From 20101125
20	WG9725240113	选档软轴总成	Flexible cable-select gear	1	To 20101125
21	WG9725240208	操纵器	Shifting device	1	From 20101125
21	WG9725240108	操纵器 (左置车)	Shifting device	1	To 20101125
22	Q40308	弹簧垫圈	Spring washer	1	
23	Q150B0816	六角头螺栓	Screw	1	
24	Q40008	小垫圈	Washer	6	
25	Q218B0825	内六角圆柱头螺钉	Screw	6	
26	Q40312	弹簧垫圈	Spring washer	1	
27	Q340B12	I型六角头螺母	Nut	1	
28	Q150B0615	六角头螺栓	Screw	1	
29	Q40106	平垫圈	Washer	2	
	AZ9725240126	套管	Bush	1	To 20110107
	Q67918	对称双管夹片	Clip	4	To 20101125
	AZ9725240003	垫圈	Washer	1	To 20101125
	AZ9725240026	软轴保护胶套	Protect sleeve	2	To 20101125

	AZ9725240028	软轴保护胶套	Protect sleeve	2	To 20101125
	Q150B0625	六角头螺栓	Screw	1	To 20101125

3.3.02 离合器液压操纵装置/Operating System

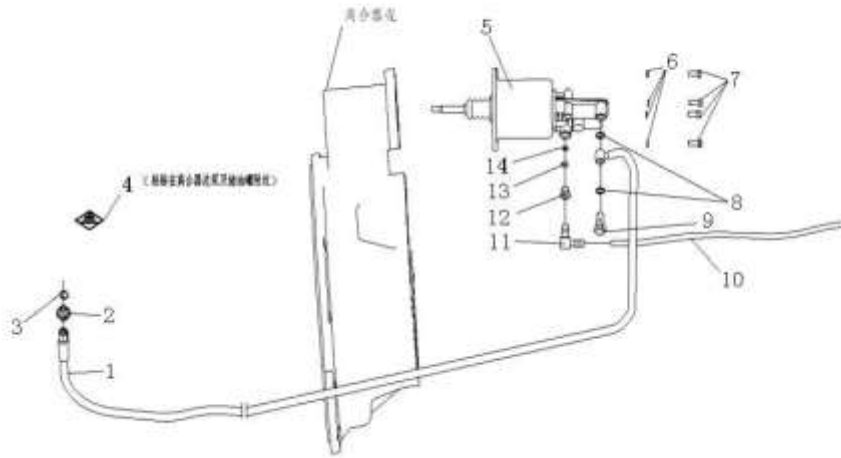

3.3.02 离合器液压操纵装置/Operating System

序号	零部件图号	名称	Part Name	数量	备注
No.	Part No.			Qty	Remark
1	WG9719230027	高压软管	Hose	1	
2	AZ9160230092	端直通接头体	"L" shape connector	1	
3	Q72314T5F	密封垫圈	Washer	1	
4	WG9114230019	离合器制动液标牌	Nameplate	1	
5	WG9725230051	离合器助力缸 (Φ102、	Operating cylinder	1	
6	Q41208	外锯齿锁紧垫圈	Washer	4	
7	Q150B0818	六角头螺栓	Screw	4	
8	Q72314T5F	密封垫圈	Washer	2	
9	190003962621	空心螺栓	Female screw	1	
10	190003179781	聚酰胺管 (Φ8*1)	Plastic pipe	100	
11	WG9000361201	直角接头体NG8/NW6	"L" shape connector	1	
12	WG9000361006	螺母座NG8	Nut seat	1	
13	WG9000361005	卡簧NG8	Clam spring	1	
14	WG9000361004	弹性元件NG8	Spring part	1	
	Q150B0830	六角头螺栓	Screw	4	To 20110304

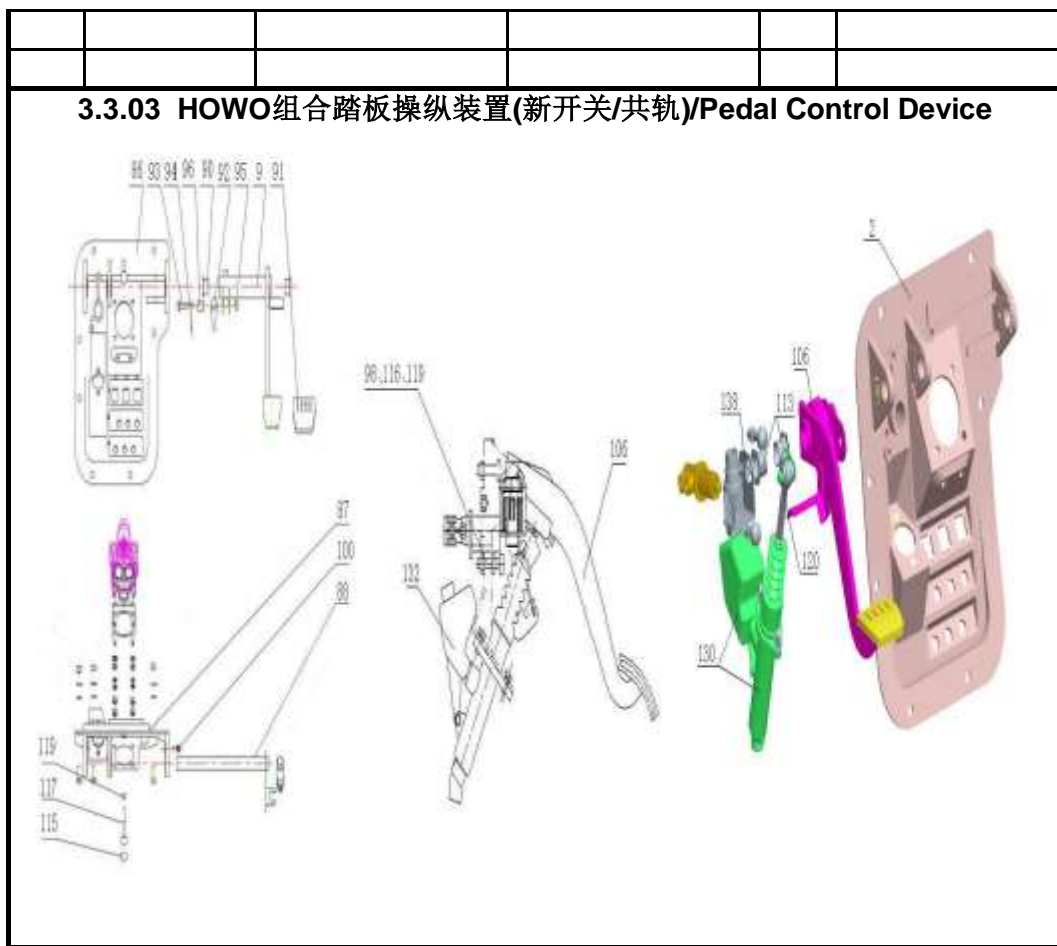

3.3.03 HOWO组合踏板操纵装置(新开关/共轨)/Pedal Control Device

序号	零部件图号	名称	Part Name	数量	备注
No.	Part No.			Qty	Remark
2	AZ9725361021	HOWO组合踏板操纵总成	Pedal ass.	1	
6	AZ9719360052	芯轴	Central spindle	1	
7	AZ9719360053	支架	Bracket	1	
9	AZ9719360056	轴	Shaft	1	
12	AZ9719360059	限位支架	Bracket	1	
13	AZ9719360066	支架	Bracket	1	
75	WG9000361007	弹性元件NG12	Connector NG12	4	
77	WG9000361008	卡簧NG12	Snap spring NG12	4	
79	WG9000361009	螺母座NG12	Nut seat NG12	4	
86	AZ9725360020	组合支架	Bracket	1	
88	AZ9719360051	芯轴总成	Shaft ass.	1	
89	AZ9719360055	制动踏板总成	Brake foot pedal	1	
90	AZ9719360060	自润滑衬套	Sleeve	2	
91	AZ9123230226	踏板橡胶罩	Rubber cover	1	
92	AZ9719360063	挺杆	Push rod	1	
93	Q173B0845	六角头螺杆带孔螺栓	Screw	1	
94	Q5002016	开口销	Split pin	1	
95	Q341B08	I型六角螺母-细牙	Nut	1	

96	AZ9719360062	销轴	Shaft	1	
97	Q150B0845	六角头螺栓	Screw	1	

3.3.03 HOWO组合踏板操纵装置(新开关/共轨)/Pedal Control Device

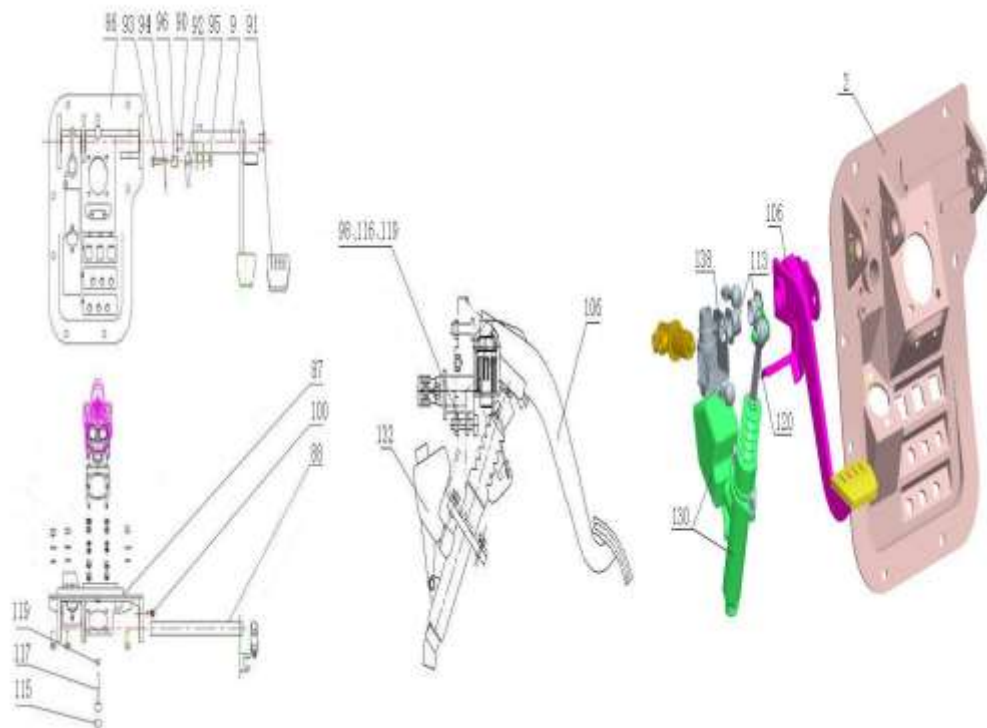

3.3.03 HOWO组合踏板操纵装置(新开关/共轨)/Pedal Control Device

序号	零部件图号	名称	Part Name	数量	备注
No.	Part No.			Qty	Remark
98	AZ9123360067	堵头	Plug	1	
99	Q340B08	1型六角螺母	Nut	1	
100	Q1840616	六角法兰面螺栓	Screw	1	
101	WG9000360520	制动总阀	Foot Brake Valve	1	
102	Q33208	2型全金属六角锁紧螺母	Nut	4	
103	Q40308	弹簧垫圈	Spring washer	4	
106	AZ9719230225	离合器踏板总成	Clutch foot pedal ass.	1	
106a	AZ9123360113	踏板	Clutch foot pedal	1	
106b	AZ9719230044	离合器踏板臂	Clutch foot pedal arm	1	
106c	AZ9719230022	限位角板	Angle plate	1	
106d	AZ9719230005	离合器踏板轴轴套	Shaft sleeve	1	
106e	AZ9719230053	支架	Bracket	1	
106f	AZ9719230224	支架	Bracket	1	
113	AZ9719360060	自润滑衬套	Sleeve	2	
114	AZ9123230226	踏板橡胶罩	Rubber cover	1	
115	AZ9123360067	堵头	Plug	2	
116	Q150B0830	六角头螺栓	Screw	1	
117	Q150B0845	六角头螺栓	Screw	1	

118	Q40308	弹簧垫圈	Spring washer	2	
119	Q340B08	I型六角螺母	Nut	2	

3.3.03 HOWO组合踏板操纵装置(新开关/共轨)/Pedal Control Device

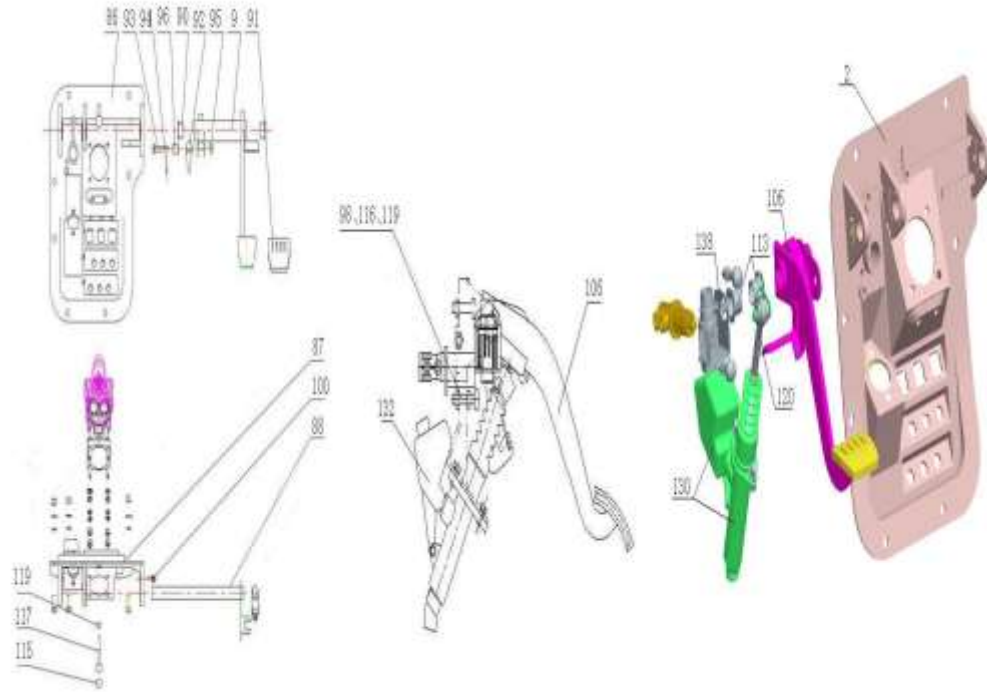

3.3.03 HOWO组合踏板操纵装置(新开关/共轨)/Pedal Control Device

序号	零部件图号	名称	Part Name	数量	备注
No.	Part No.			Qty	Remark
120	AZ9719230228	销轴总成	Shaft ass.	1	
123	Q150B0616	六角头螺栓	Screw	1	
124	Q40106	平垫圈	Washer	1	
125	Q40306	弹簧垫圈	Spring washer	1	
126	Q340B06	I型六角螺母	Nut	1	
127	AZ9719230222	离合器总泵推杆	Rod ass.	1	
128	AZ9123230053	无内圈滚针轴承	Needle bearing	1	
129	AZ9719230229	垫圈	Washer	2	
130	WG9719230023	离合器总泵及储油罐总成	Clutch pump and tank ass.	1	
130,1	WG9719230014	离合器储油罐	Tank	1	
130,2	WG9719230015	离合器总泵	Clutch pump	1	
133	AZ9719230231	弹簧座	Spring seat	1	
134	Q150B0820	六角头螺栓	Screw	2	
135	Q40108	平垫圈	Washer	2	
136	Q40308	弹簧垫圈	Spring washer	2	
137	AZ9719230232	回位弹簧	Spring	1	
138	AZ9719230058	信号开关支架	Switch bracket	1	
142	WG9718710005	离合器开关	Clutch switch	1	

143	AZ9719230021	密封堵(内饰件厂)	Plug	1	
144	WG9725716002	双触点制动灯开关	Brake lamp switch	1	

3.3.04 传动轴/Propeller Shaft

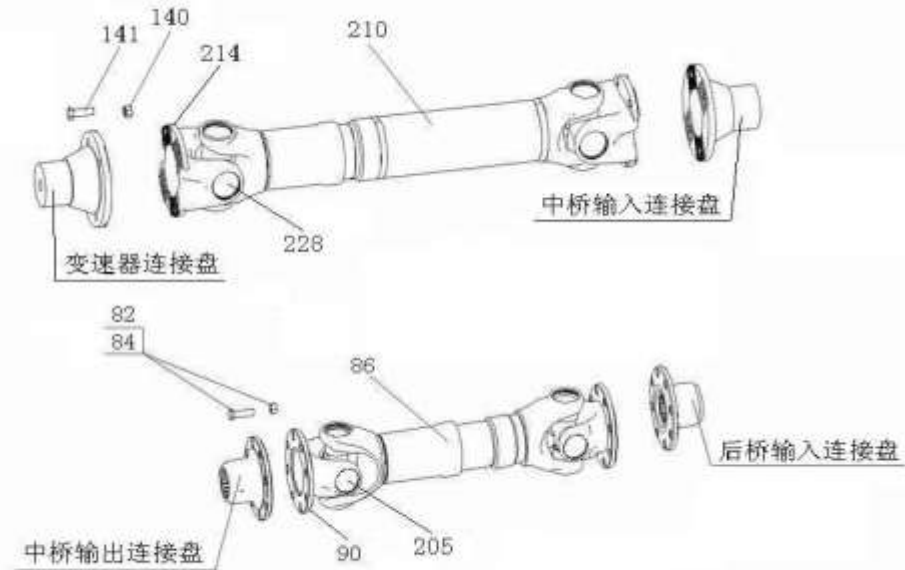

3.3.04 传动轴/Propeller Shaft

序号	零部件图号	名称	Part Name	数量	备注
No.	Part No.			Qty	Remark
82	190003888459	自锁螺母	Nut	16	
84	WG9012310124	六角头螺栓	Screw	16	
86	AZ9114310126	中后桥传动轴	Propeller shaft	1	
90	26013314062	传动轴连接盘	Flange	2	
140	AZ9003888458	自锁螺母(14×1.5, 10级)	Nut	8	
141	Q151B1450TF3	六角头螺栓	Screw	8	
205	WG6013314080	万向节总成	Universal joint	2	
210	AZ9939311310	传动轴	Propeller shaft	1	
214	AZ9315313635	传动轴连接盘(Φ62×160)	Flange	2	
228	WG9725310020	万向节总成(Φ62*160)	Universal joint	2	

3.3.05 变速器辅助支撑/Transmission Support

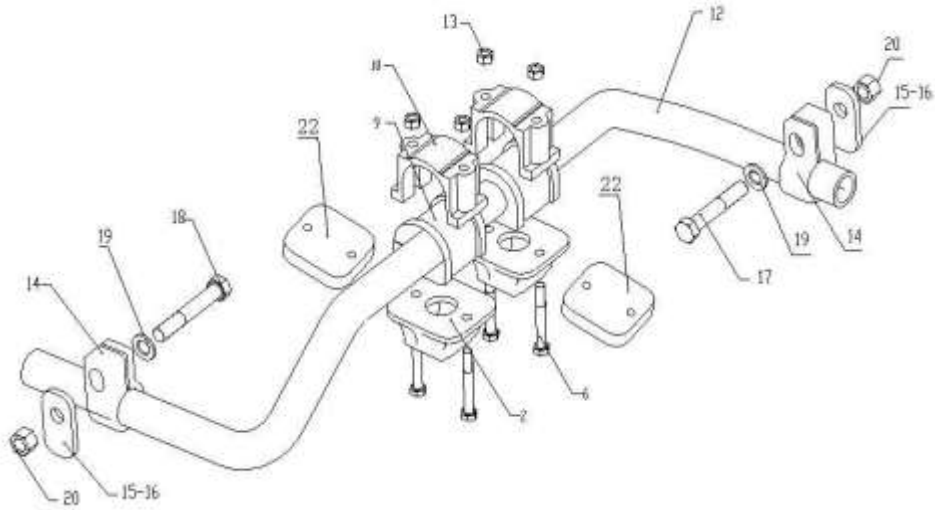

3.3.05 变速器辅助支撑/Transmission Support

序号 No.	零部件图号 Part No.	名称	Part Name	数量 Qty	备注 Remark
2	WG9725590319	支架	Bracket	2	
6	Q150B1080	六角头螺栓	Screw	4	
9	199100680068	橡胶轴承	Bearing	2	
10	1880 680024	固定夹块	Block	2	
12	AZ9725590367	弯管	Pipe	1	
13	Q33210	2型全金属六角锁紧螺母	Nut	4	
14	AZ9725590313	管夹	Clamp	2	
15	AZ9725590309	垫板	Plate	2	
16	AZ9725590310	垫板	Plate	2	
17	Q150B1685	六角头螺栓	Screw	1	
18	Q150B16100	六角头螺栓	Screw	1	
19	Q40116	平垫圈	Washer	2	
20	Q33216	自锁螺母	Nut	2	
22	WG9725590323	垫板	Plate	2	

--	--	--	--	--	--